



☼ Supplier: 3525

闸阀 Gate Valve

设计标准 Design Standard	API600/BS1414/BSEN12288/MSSSP80 BS5154Aseries /BSENISO10434
口径范围 DN Range	DN8~DN1050
额定压力 Rated Pressure	ANSI150~1500



☞ Code:130122

☼ 供应商: 2126,2383,2385

☼ Supplier: 2126,2383,2385

CB/T465-1995 法兰铸铁闸阀 Marine Iron Flanged Gate Valve

Type A

公称口径DN(mm)	50 ~ 150	175 ~ 300
公称压力PN(MPa)	0.6	0.4
壁厚Wall Thickness(mm)	8 ~ 10	11 ~ 13
升程Lift(m)	60 ~ 165	190 ~ 315
重量Weight(kg)	20 ~ 70	85 ~ 199

Type AS

公称口径DN(mm)	50 ~ 150	175 ~ 300	350 ~ 500
------------	----------	-----------	-----------

公称压力PN(MPa)	0.6	0.4	0.25
壁厚Wall Thickness(mm)	8 ~ 10	11 ~ 13	14 ~ 16
升程Lift(m)	60 ~ 165	190 ~ 315	365 ~ 518
重量Weight(kg)	20.3 ~ 71.6	86.4 ~ 201.2	298.3 ~ 627.4

↓ Notes: Certificate ABS, BV, CCS, LR.

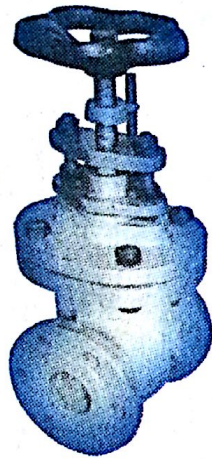

Code: I30123

☼ 供应商: 2115

☼ Supplier: 2115

CB/T465-1995 法兰铸铁闸阀 Cast Iron Gate Valve

型号 Type	公称口径DN(mm)	公称压力PN(MPa)	适用介质 Application Medium
A	50 ~ 150	0.6	Sea Water, Lubricant Oil, Fresh Water
AS	175 ~ 300	0.4	
AS	350 ~ 500	0.4	

↓ Notes: Certificate CCS.

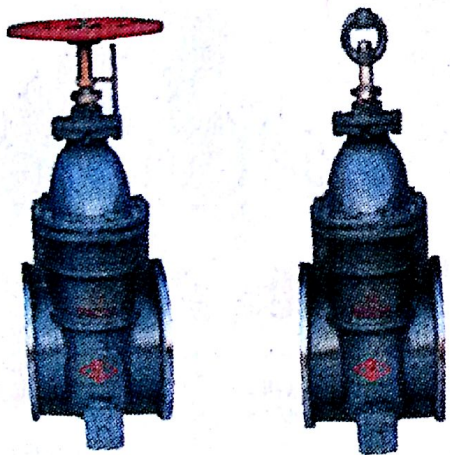

Code: I30124

☼ 供应商: 2137, 2336, 2454, 2388

☼ Supplier: 2137, 2336, 2454, 2388

GB1857-80, CB/T3591-94 油轮闸阀 Gate Valve for Oil Tanker

公称口径DN(mm)	公称压力PN(MPa)	适用介质 Application Medium
50 ~ 400	1.0	Sea Water, Fresh Water

↓ Notes: Certificate: CCS, ZC, ZY.

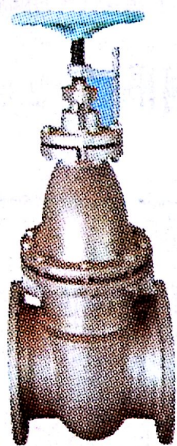

Code: I30126

☼ 供应商: 2126,2383

☼ Supplier: 2126,2383

CB/T466-1995 法兰铸钢闸阀 Cast Steel Flanged Gate Valve
Type A

公称通径DN(mm)	50 ~ 100	125 ~ 150	175 ~ 300	350 ~ 500
公称压力PN(MPa)	1.0	0.6	0.4	0.25
升程Lift(m)	60 ~ 112	138 ~ 165	190 ~ 315	365 ~ 518
重量Weight(kg)	18 ~ 28	41 ~ 51	70 ~ 134	219 ~ 519

Type AS

公称通径DN(mm)	50 ~ 100	125 ~ 150	175 ~ 300	350 ~ 500
公称压力PN(MPa)	1.0	0.6	0.4	0.25
升程Lift(m)	60 ~ 112	138 ~ 165	190 ~ 315	365 ~ 510
重量Weight(kg)	20.3 ~ 41.2	62.1 ~ 71.6	86.4 ~ 201.2	298.3 ~ 627.4

⚓ Notes: Certificate ABS, BV, CCS, LR.

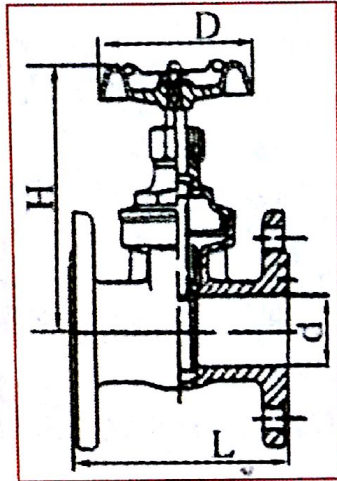
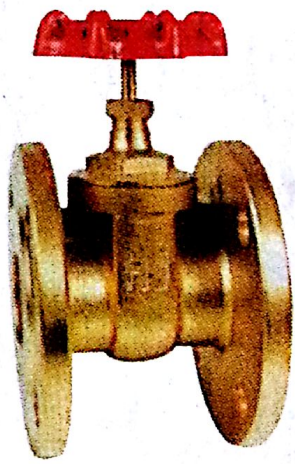

黄铜法兰闸阀 Brass Gate Valve (flanged)
Unit: mm

公称通径DN		50 ~ 100
通水孔直径Hole Dia.	d	45 ~ 90
长Length	L	125 ~ 180
中心高Center Height	H	138 ~ 242
手轮直径Handwheel Dia.	D	110 ~ 200

Code: I30131

☼ 供应商: 2207

☼ Supplier: 2207

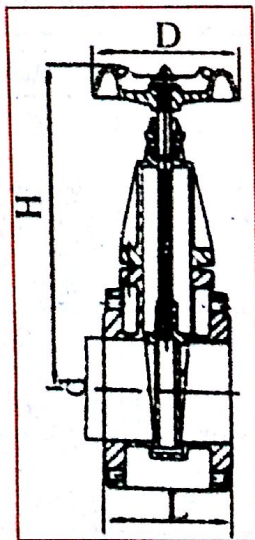
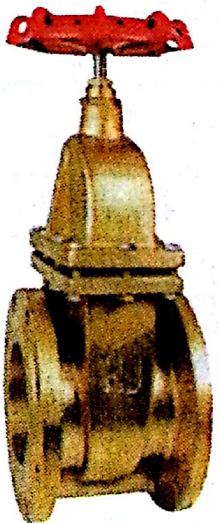

黄铜法兰闸阀 Brass Gate Valve (flanged)
Unit: mm

公称通径DN		125/150/200
通水孔直径Hole Dia.	d	125/150/200
长Length	L	170/190/230
中心高Center Height	H	382/430/520
手轮直径Handwheel Dia.	D	200/240/300

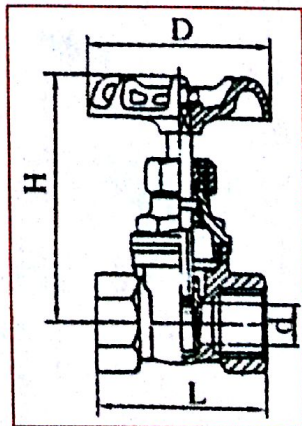

Code: I30132

☼ 供应商: 2207

☼ Supplier: 2207

JIS F 7366 船用10K铸铁闸阀

Cast Iron 10K Gate Valves For Marine Use

Unit:mm

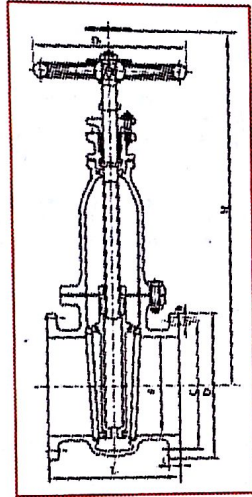
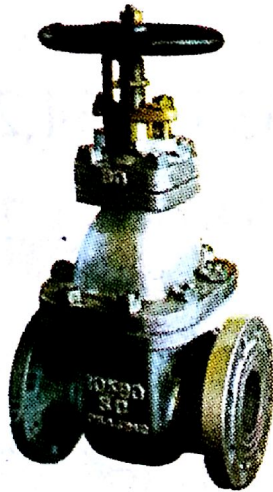

公称通径DN	50 ~ 300
L	200 ~ 380
D	155 ~ 445
C	120 ~ 400
h	19 ~ 25
N	M16 ~ M22
H	300 ~ 960
t	16 ~ 24
DI	140 ~ 450

Code:130139

☼ 供应商: 2377

☼ Supplier: 2377

JIS F 7366 铸钢闸阀 Cast Steel 10K Gate Valves

Unit: mm

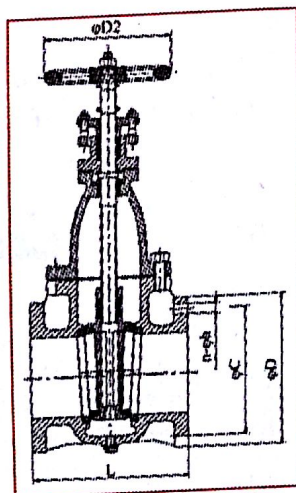

公称通径 DN	50~100	
L	200~250	
D2	140~200	
H	300~450	
法兰尺寸 Flanged Size	D	155~210
	n	4/8
	h	19
	C	120~175
重量 Weight (kg)	17.1~44.9	

↓ Notes: Certificate CCS, CE.

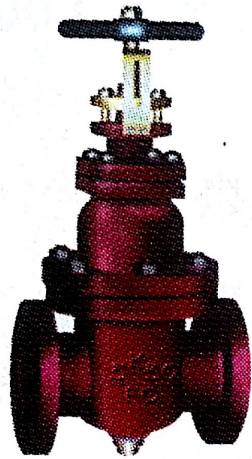

Code: I30042

☼ 供应商: 2128

☼ Supplier: 2128

JIS船用法兰铸铁闸阀 Marine Cast Iron Gate Valve

型号 Type (kg/cm ²)		5			10		
公称通径 DN (mm)		≤200	250 ~ 400	450 ~ 600	≤200	250 ~ 400	450 ~ 600
最大工作压力 Max. Working Pressure (MPa)	饱和蒸汽 Saturated Steam	0.3	0.2	0.2	0.5	0.3	0.3
	油类和脉动的水 Oil and Pulsation Water	0.5	0.5	0.5	1.0	1.0	1.0
	非冲击水 Non Shockwater < 120°C	0.7	0.7	0.5	1.4	1.4	1.2
制造标准 Standard		JIS F7363			JIS F7364		

↓ Notes: 1. Used in the medium pipe run such as fresh water, sea water, oil product, gas, steam etc. 2. Certificate CCS.

JIS F 7368 青铜闸阀

Bronze 10K Rising Stem Type Gate Valves

Unit: mm

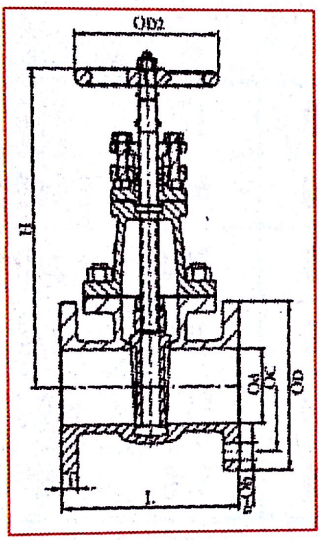

公称通径 DN	15~65
L	100~220
D	95~175
H	175~302
D2	80~140
C	70~140
N	4
H	15/19
重量 Weight (kg)	2.96~9.71

↓ Notes: Certificate CCS, CE.



Code: I30146

✿ 供应商: 2040

✿ Supplier: 2040

JIS F 7367/JIS F 7368 船用青铜闸阀
Marine Bronze Rising Stem Gate Valve

Unit:mm

		5kgf/cm ² (F7367)	16kgf/cm ² (F7368)
规格Size		15 ~ 40	15 ~ 40
长Length		90 ~ 140	100 ~ 150
法兰Flange	直径Dia.	80 ~ 120	95 ~ 140
	节圆直径PCD	60 ~ 95	70 ~ 105
	螺栓孔Bolt Hole	4-12 ~ 4-15	4-15 ~ 4-19
高Height		175 ~ 290	175 ~ 290
手轮直径Handwheel Dia.		80 ~ 125	80 ~ 125
重量Weight(kg)		2.29 ~ 7.78	2.96 ~ 9.17
工作压力 Working Pressure	蒸汽Steam Up to 205°C	5	10
	油和脉动的水Oil and Pulsation Water	2	2
	非冲击水Non Shock Water (≤120°C)	7	14

↓ Notes: Certificate ABS, BV, CCS, DNV.