

# JIS F 7306 铸铁角式截止阀

## Cast iron 5K Angle Valves

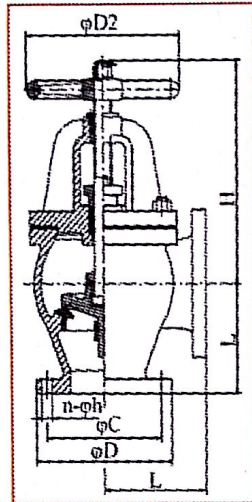

Unit: mm

公称通径 DN	50~400	
L	100~395	
D2	160~560	
H	240~770	
法兰尺寸 Flanged Size	D	130~540
	C	105~495
	n	4~16
	h	15~25
重量 Weight (kg)	12.90~459.00	

⚓ Notes: Certificate CCS, CE.

# IS F 7308 铸铁角式截止阀 Cast Iron 10K Angle Valves

Unit: mm

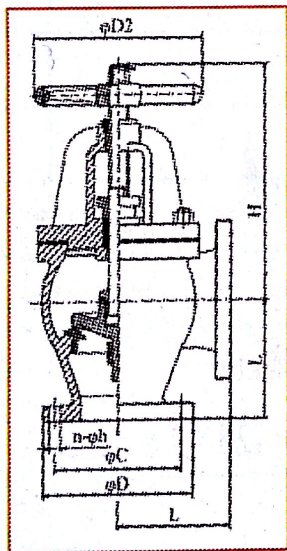
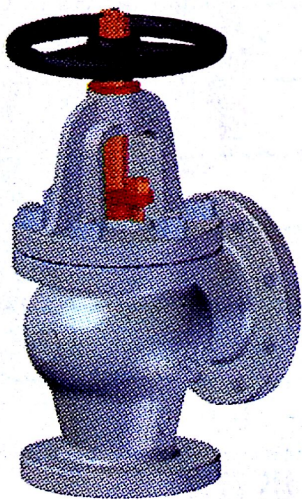

公称通径 DN	50~400	
L	120~420	
D2	160~630	
H	255~790	
法兰尺寸 Flanged Size	D	155~560
	C	120~510
	n	4~16
	h	19~27
重量 Weight (kg)	18.20~544.00	

↓ Notes: Certificate CCS, CE.

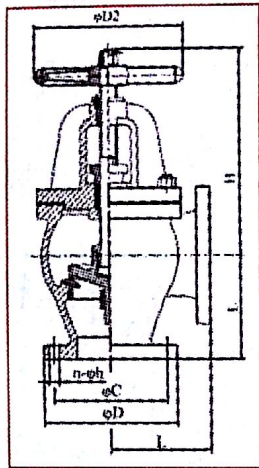
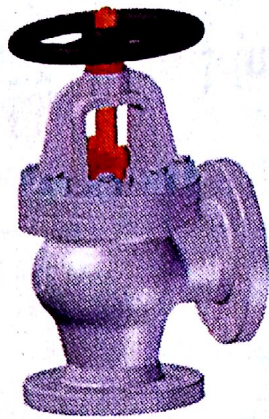

公称通径 DN	50~200	
L	120~250	
D2	160~450	
H	255~540	
法兰尺寸 Flanged Size	D	155~350
	C	120~305
	n	8/12
	h	19~25
重量 Weight (kg)	18.00~155.00	

⚓ Notes: Certificate CCS, CE.

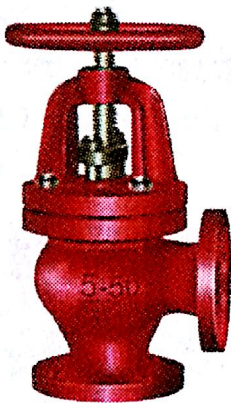

Code: I30095

⊗ 供应商: 2128

⊗ Supplier: 2128

### JIS船用法兰铸铁直角截止阀 Marine Cast Iron Angle Stop Valve

公称通径 DN (mm)		5(kg/cm <sup>2</sup> )			10(kg/cm <sup>2</sup> )			16(kg/cm <sup>2</sup> )
		≤200	250 ~ 300	350 ~ 400	≤200	250 ~ 300	350 ~ 400	≤200
最大工 作压力 Max. Working Pressure (MPa)	≤230°C Steam	0.5	0.5	-	1.0	0.5	-	1.6
	Air or Gas	0.5	0.5	-	1.0	0.5	-	1.6
	油类和脉动的水 Oil and Pulsation Water	0.5	0.5	0.5	1.0	0.5	0.5	1.6
	<120°C非冲击水 Non Shock Water of 120°C or Less	0.7	0.7	0.6	1.4	1.0	1.0	2.2
制造标准 Standard		JIS F7306			JIS F7308			JIS F7310

⚓ Notes: 1. Used in the medium pipe run such as fresh water, sea water, oil product, gas, steam etc.  
2. Certificate CCS.

# JIS F 7320 铸钢角式截止阀 Cast Steel 10K Angle Valves Unit: mm

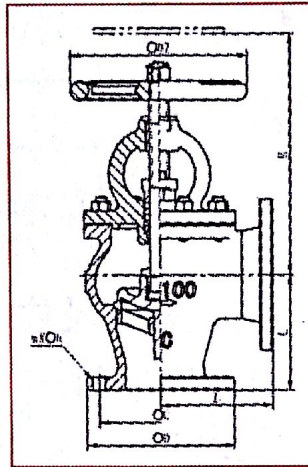

公称通径 DN	50~100	
L	120~160	
D2	160~250	
H	270~355	
法兰尺寸 Flanged Size	D	155~210
	n	4/8
	h	19
	C	120~175
重量 Weight (kg)	16.3~37	

↓ Notes: Certificate CCS, CE.



**Code: I30097**

☼ 供应商: 2128

☼ Supplier: 2128

# JIS 7312/7320 船用铸钢直角截止阀 Marine Cast Steel Angle Stop Valve

		5(kg/cm <sup>2</sup> )	10(kg/cm <sup>2</sup> )
公称通径DN (mm)		≤300	≤300
最大工作压力 Max. Working Pressure (MPa)	300°C Steam	-	1.0
	≤220°C Steam	-	1.2
	Air or gas	-	
	油类和脉动的水 Oil and Pulsation Water	0.5	1.4
	<120°C 非冲击水 Non Shockwater of 120°C or Less	0.7	
制造标准 Standard		JIS F7312	JIS F7320

↓ Notes: 1. Used in the medium pipe run such as fresh water, sea water, oil product, gas, steam etc.  
2. Certificate CCS.

# JIS F 7354 铸铁角式截止止回阀

Cast Iron 5K Screw-down Check Angle Valves

Unit: mm

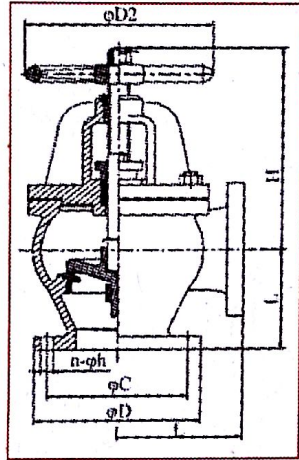

公称通径 DN	50~550	
L	100~530	
D2	160~800	
H	240~935	
法兰尺寸 Flanged Size	D	130~720
	C	105~665
	n	4~20
	h	15~27
重量 Weight (kg)	13.00~1161.00	

↓ Notes: Certificate CCS, CE.

Code: 130101

☼ 供应商: 2377

☼ Supplier: 2377

# JIS F 7376 铸铁角式截止止回阀

Cast Iron 10K Screw-down Check Angle Valves

Unit: mm

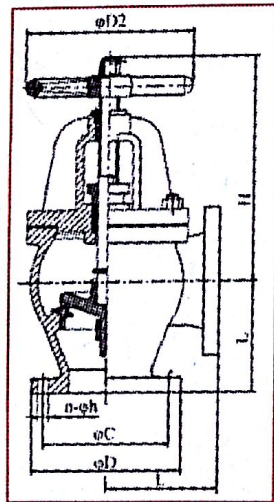
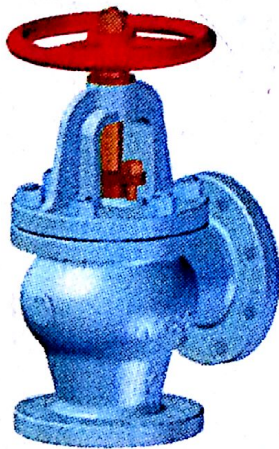

公称通径 DN	50~200	
L	120~230	
D2	160~355	
H	255~450	
法兰尺寸 Flanged Size	D	155~330
	C	120~290
	n	4~12
	h	19/23
重量 Weight (kg)	18.20~124.00	

↓ Notes: Certificate CCS, CE.

# JIS F 7410 青铜角式截止止回阀

## Bronze 16K Screw-down Check Angle Vales

Unit: mm

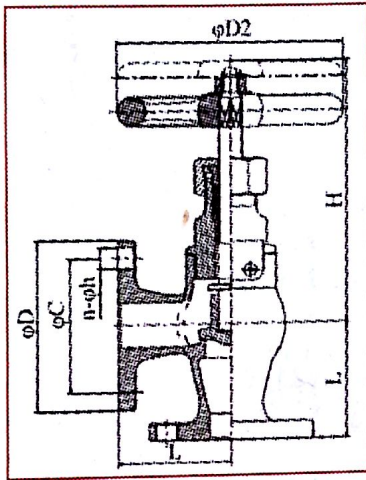
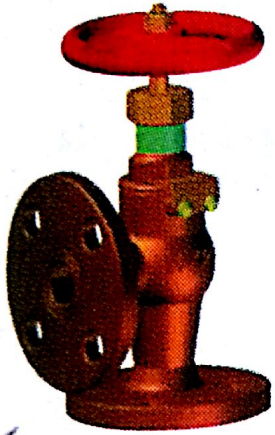

公称通径 DN	15~40
L	70~100
D	95~140
H	120~160
D2	80~140
N	4
H	15/19
重量 Weight (kg)	2.67~7.95

↓ Notes: Certificate CCS, CE.

Code: 130105

供应商: 2377

Supplier: 2377

# JIS F 7352 青铜角式截止止回阀

## Bronze 5K Screw-down Check Angle Valves

Unit: mm

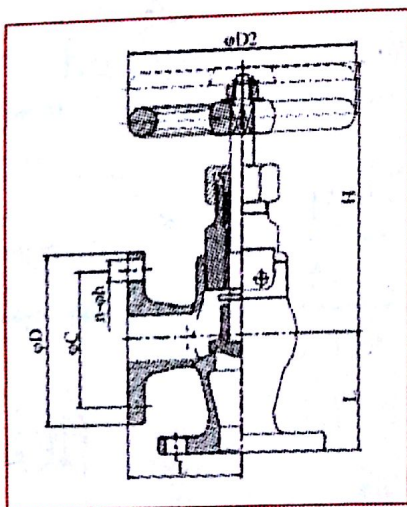

公称通径 DN	15~40	
L	55~85	
D2	80~140	
H	120~160	
法兰尺寸 Flanged Size	D	80~120
	C	60~95
	n	4
	h	12/15
重量 Weight (kg)	1.92~5.81	

↓ Notes: Certificate CCS, CE.

# JIS船用铸钢角形升降式止回阀

Cast Steel Screw-down Check Angle Valves for Marine Use JIS F 7472  
Unit:mm

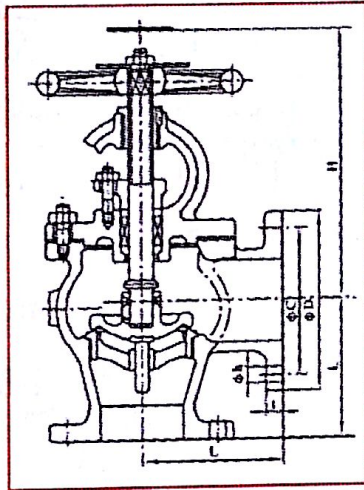
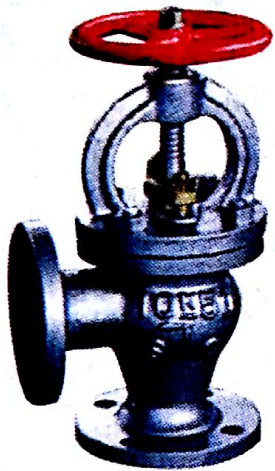

型号Type	10 K	20 K
	JIS F 7472	JIS F 7474
规格Size	50 ~ 200	32 ~ 250
L	120 ~ 230	100 ~ 310
D	155 ~ 330	135 ~ 430
C	120 ~ 290	100 ~ 380
t	16 ~ 22	18 ~ 34
Φh	4Φ19 ~ 12Φ23	4Φ19 ~ 12Φ27
N	M16 ~ M20	M16 ~ M24
H	235 ~ 460	240 ~ 595

Code: I30109

☼ 供应商: 2377

☼ Supplier: 2377

# JIS F 7416 青铜角式升降式止回阀 (组合阀盖式)

Bronze 5K Lift Check Angle Valves (Union Bonnet Type) Unit: mm

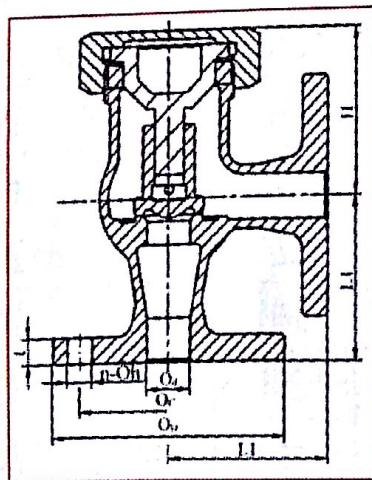
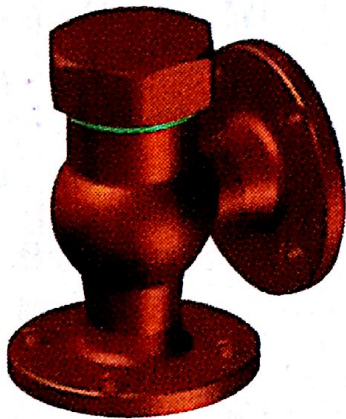

公称通径 DN	15~40
LI	55~85
H	56~69
T	9~12
法兰尺寸 Flanged Size	D 80~120
	n 4
	h 12/15
	C 60~95

†. Notes: Certificate CCS, CE.

JIS船用铸铁角形阀 Cast Iron Angle Valves

Unit:mm

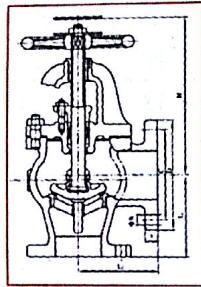

型号Type	5K/JIS F 7306	10 K/JIS F 7308	16 K/JIS F 7310
规格Size	50 ~ 400	50 ~ 400	50 ~ 200
L <sub>1</sub>	100 ~ 395	120 ~ 420	120 ~ 250
D	130 ~ 540	155 ~ 560	155 ~ 350
C	105 ~ 495	120 ~ 510	120 ~ 305
t	16 ~ 30	20 ~ 36	20 ~ 30
Φ h	4Φ 15 ~ 16Φ 25	4Φ 19 ~ 16Φ 27	8Φ 19 ~ 12Φ 25
N	M12 ~ M22	M16 ~ M24	M16 ~ M22
H	240 ~ 770	255 ~ 790	255 ~ 540

Code:130112

☼ 供应商: 2338,2433

☼ Supplier: 2338, 2433

JIS船用铸钢角形阀 Cast Steel Angle Valves

Unit:mm

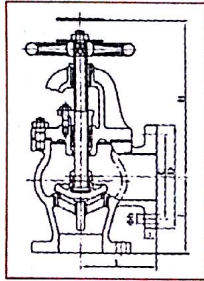
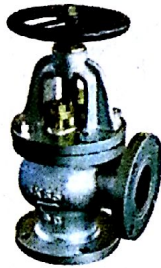

型号Type	5 K/JIS F 7312	10 K/JIS F 7320	20 K/JIS F 7314
规格Size	50 ~ 300	50 ~ 300	32 ~ 250
L	100 ~ 310	120 ~ 320	100 ~ 310
D	130 ~ 430	155 ~ 445	135 ~ 430
C	105 ~ 390	120 ~ 400	100 ~ 380
t	14 ~ 22	16 ~ 24	18 ~ 34
Φ h	4Φ 15 ~ 12Φ 23	4Φ 19 ~ 16Φ 25	4Φ 19 ~ 12Φ 27
N	M12 ~ M20	M16 ~ M22	M16 ~ M24
H	240 ~ 748	240 ~ 610	250 ~ 620

Code:130113

☼ 供应商: 2548

☼ Supplier: 2548

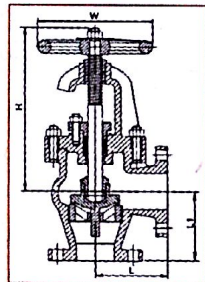
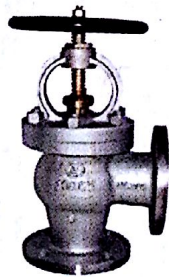

JIS船用铸钢角阀 Marine Cast Steel Angle Valve

Unit: mm

公称通径DN		50	65	80	100	125	150	200	250	300
5kgf/cm <sup>2</sup> (JISF7312)	H	238	252	263	310	328	377	450	644	750
	L	100	115	130	150	170	190	220	275	310
	L1	100	115	130	150	170	190	220	275	310
	W	160	180	180	224	250	280	315	355	400
	kg	13	18.5	23.8	34.1	46.3	63.8	104	177	270
10kgf/cm <sup>2</sup> (JISF7320)	H	244	263	266	301	348	398	477	531	610
	L	120	130	140	160	180	205	230	290	320
	L1	120	130	140	160	180	205	230	290	320
	W	160	200	200	250	280	315	355	400	450
	kg	16.1	22.8	25.2	36.8	56.9	76.8	115.5	188	252
20kgf/cm <sup>2</sup> (JISF7314)	H	277	306	341	383	438	484	541	621	-
	L	125	135	150	170	200	225	280	310	-
	L1	125	135	150	170	200	225	280	310	-
	W	200	224	250	280	315	365	450	560	-
	kg	19.8	27.2	39.2	54.5	79.9	111.5	180.5	282	-

↓ Notes: The flanges shall conform to 5kgf/cm<sup>2</sup> of JIS B2211, 10kgf/cm<sup>2</sup> of JIS B2212 and 20kgf/cm<sup>2</sup> JIS B2214.