

液压绞车 Hydraulic Winch

滚筒负载 Capacity(kN)	公称速度 Nominal Speed(r/min)	绳索直径 Rope Dia.(mm)	转速范围 Speed(r/min)	外形尺寸 Dimension(mm)
15	0-9	20	2-200	805 × 800 × 973
30	0-13.2	22	3-250	1615 × 1100 × 1260
50	0-15	20.5	3-250	2050 × 1080 × 1150
80	0-9	27	3-125	1995 × 1330 × 1700
80	0-15	26	3-175	2085 × 1180 × 1800
100	0-17	26	3-125	2085 × 1780 × 1500
100	0-15	28	3-175	2090 × 2100 × 1680
120	0-15	30	3-175	2120 × 2100 × 1680
160	0-15	38	3-175	2140 × 2200 × 1700
200	0-15	40	3-175	2350 × 2200 × 1700
250	0-15	40	3-175	2400 × 2250 × 1750
300	0-6	40	0.5-125	4930 × 2514 × 1841

↓ Notes: Rated Pressure 16/20MPa.

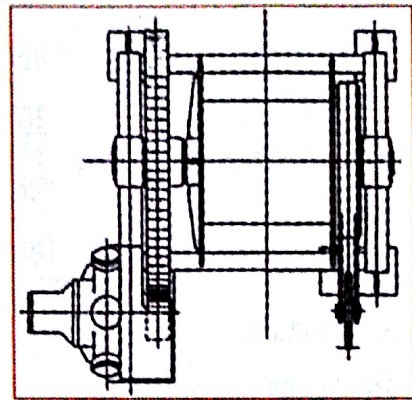
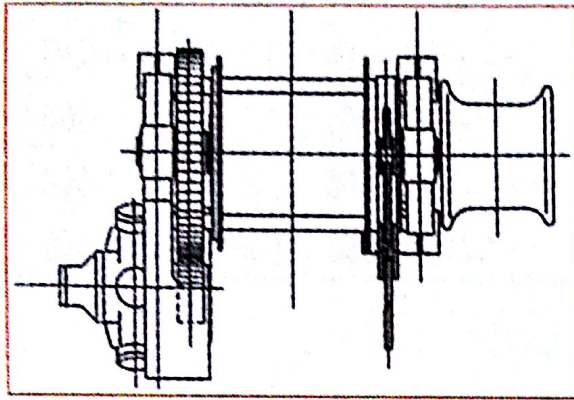

### 液压绞车/吊车 Hydraulic Cargo Winch & Topping Winch

型号Type		3	5	7.5	10
额定负载Rated Load(t)		3	5	7.5	10
额定速度Rated Speed(r/min)		30/36	30/36	20/25	20
绳径Wire Dia. (mm)		20	24	26	32
链筒尺寸 Drum Size.(mm)	Dia	380	450	500	550
	Length	450	560	650	700
卷筒 Warping Drum	Rated Load(t)	1.5	2	3	4
	Drum Size(mm)	φ 320 × 360L	φ 350 × 400L	φ 400 × 450L	φ 450 × 500L
液压马达扭矩Hydraulic Motor Torque(kg/m)		260	440	710	710

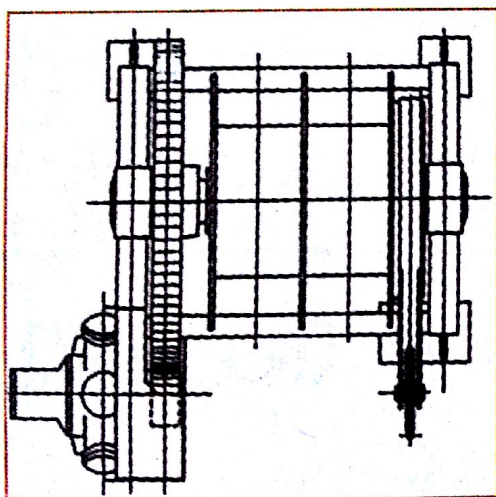

Code: 170146

※ 供应商: 3193

※ Supplier: 3193

### 液压绞车 Hydraulic Winch

型号Type		3	5	7.5	10
额定负载Rated Load(t)		3	5	7.5	10

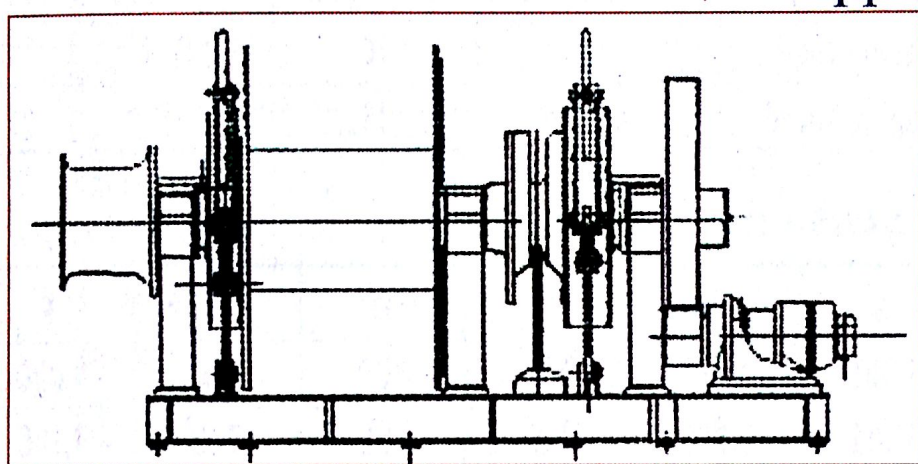

液压绞车 Hydraulic Winch

额定拉力 Rated Pull(kN)	额定速度 Rated Speed(r/min)	滚筒容绳量 Drum Capacity(m)	电机功率 Motor Power(kW)
20	≥12	φ 15 × 150	11
40	≥15	φ 17.5 × 150	22
50	≥15	φ 20.5 × 180	30
75	≥15	φ 26 × 200	45
100	≥12	φ 30 × 200	45
160	≥12	φ 30 × 250	75
250	≥9.6	φ 44.5 × 250	90
315	≥7.8	φ 52 × 250	90
400	≥7.8	φ 56 × 250	110
450	≥7.8	φ 56 × 250	132
500	≥7.8	φ 56 × 250	132
600	≥6	φ 56 × 250	132
650	≥6	φ 56 × 250	132

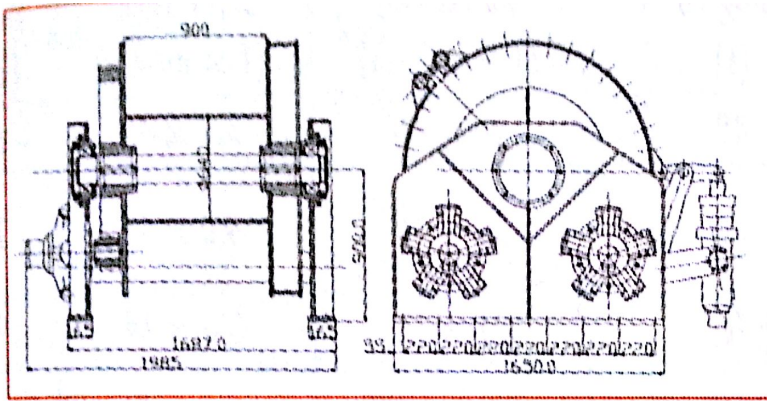

YB120液压绞车 Hydraulic Winch

Code: I70137

☼ 供应商: 2510

☼ Supplier: 2510

额定拉力 Rated Pull (kN)	额定速度 Rated Speed (r/min)	工作压力 Working Pressure (MPa)	钢索直径 Wire Rope Dia. (mm)	容绳量 Drum Capa. (m)
120	15	15	34	300

↓ Notes: Certificate CCS.

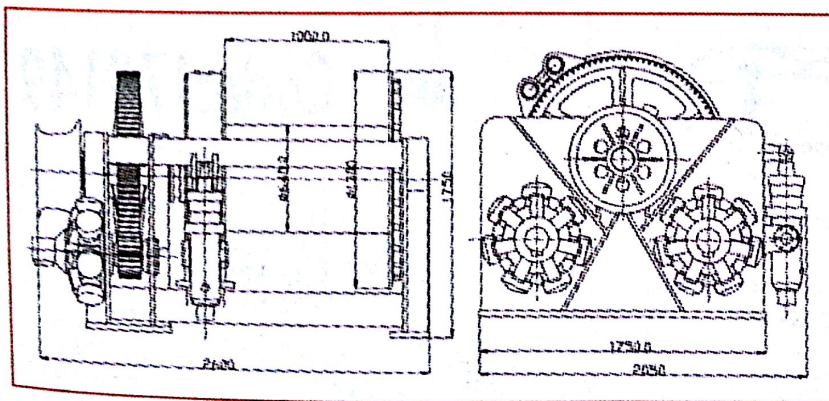

YB180液压绞车 Hydraulic Winch

Code: I70138

☼ 供应商: 2510

☼ Supplier: 2510

额定拉力 Rated Pull(kN)	额定速度 Rated Speed(r/min)	工作压力 Working Pressure(MPa)	钢索直径 Wire Rope Dia.(mm)	容绳量 Drum Capa.(m)
180	15	15	40	300

↓ Notes: Certificate CCS.

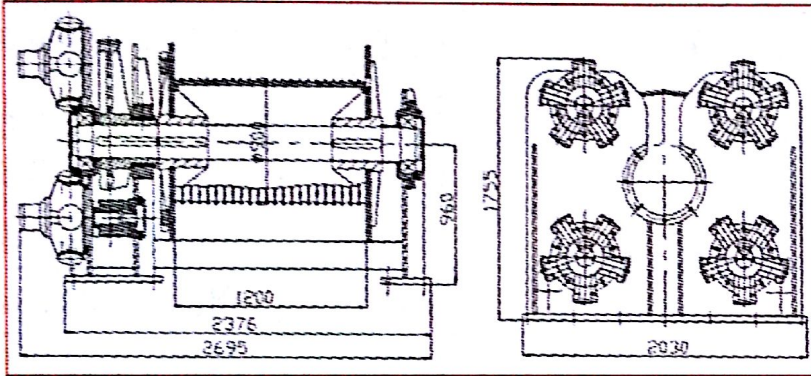

Code: I70139

☼ 供应商: 2510

☼ Supplier: 2510

YHJ350 液压绞车 Hydraulic Winch

额定拉力 Rated Pull(kN)	额定速度 Rated Speed(r/min)	工作压力 Working Pressure(MPa)	钢索直径 Wire Rope Dia.(mm)	容绳量 Drum Capa.(m)
350	20	16	44	300

↓ Notes: Certificate CCS.

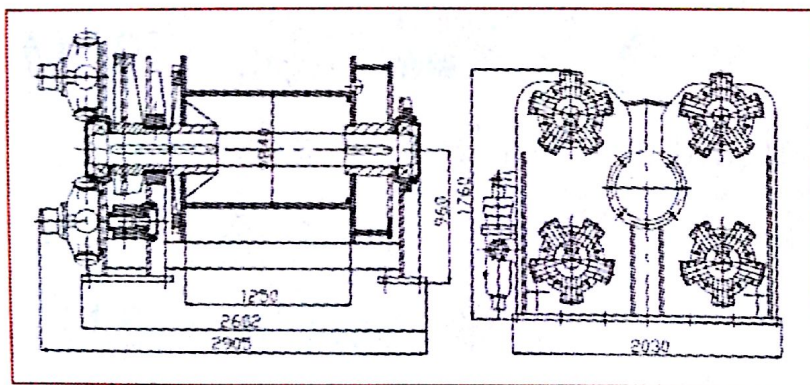

Code: I70140

☼ 供应商: 2510

☼ Supplier: 2510

YQJ400 液压绞车 Hydraulic Winch

额定拉力 Rated Pull(kN)	额定速度 Rated Speed(r/min)	工作压力 Working Pressure(MPa)	钢索直径 Wire Rope Dia.(mm)	容绳量 Drum Capa.(m)
400	20	16	52	215

↓ Notes: Certificate CCS.